

Networkfleet AT-1400 Asset Tracker

Installation Guide

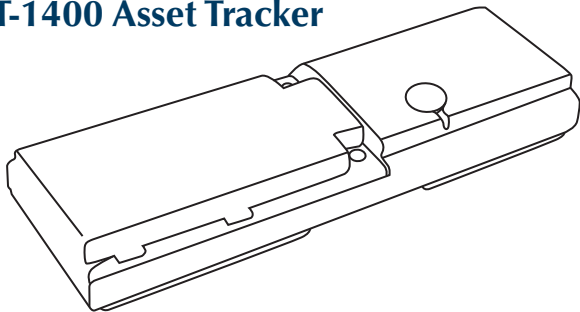

www.networkfleet.com | Customer Care: 866.227.7323 customercare@networkfleet.com



Getting Started

Registration Form & Activation.....	4
-------------------------------------	---

AT-1400 Device

Unit Overview	5-6
---------------------	-----

Installation Process

Installing the AT-1400	7-8
Installation Best Practices.....	9
Verifying Installation	10
Battery Replacement Process.....	11

Appendix

Contacting Networkfleet.....	Back Cover
------------------------------	------------

Registration Form & Activation

Fill out the enclosed registration form before completing installation. Be sure to record the Networkfleet Unit Serial Number (7 digits) along with other asset details for your records.

Networkfleet devices are shipped “cold” (not activated) from our facility. Activation is required prior to installation in order for your device to report.

networkfleet. **AT-1400** Registration Form

REGISTRATION INSTRUCTIONS

For self installations, please complete this form, then log in to: www.networkfleet.com. In the top navigation area, click on the Admin tab. Next, click the Registration button to complete the registration using the data on this form. *For Networkfleet Certified Installers, please fax your completed registration form to 866-616-2131.*

Questions? Contact Networkfleet Customer Care at 1-866-227-7323

AT-1400 Unit Overview

Networkfleet's AT-1400 provides battery powered tracking for your fixed and movable fleet assets such as trailers, sheds, generators, heavy duty equipment, and any other property that you may need to monitor.

The AT-1400 includes a replaceable battery and internal antenna.

The AT-1400 is shipped with a base configuration to report location information as follows:

- Once per day and;
- Upon movement of the asset and;
- Once per hour while the asset is moving and;
- When the asset stops moving

The configuration may be modified by contacting Customer Care at 866.227.7323.

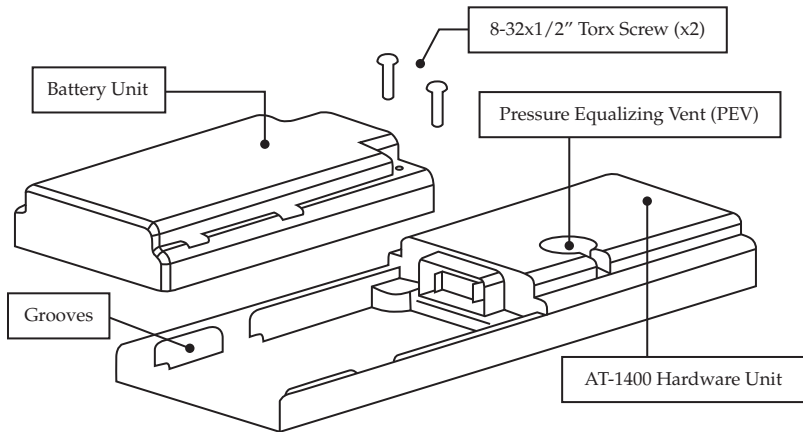

1. Activate the AT-1400. Activation is required prior to installation in order for your device to report.
2. Connect the battery by placing it on the grooves of the hardware unit. Push down and slide the battery forward until the battery overlaps with the two through-holes (for screws) on the hardware unit; some force may be required. **Note:** Once the battery is connected, the device will begin transmitting location information.
3. Screw in the two 8-32 x 1/2" torx screws (provided) to seal the battery and the unit together.

4. Find a location to secure the asset tracker to and use the enclosed alcohol preparation pad to clean the surface where the unit will be placed. For optimal operation, the AT-1400 should be placed on a flat, stationary surface with a clear view of the sky. The unit should be placed in the least obstructed location on the asset, and it should not be placed in an area completely covered by metal.
5. Remove the protective strip from the bottom of the unit to expose the adhesive tape. The use of electrical tape or any other adhesive products to secure the unit is strongly discouraged.
6. Be sure you are satisfied with the location before placing the unit. It will be **extremely** difficult to move the unit once it is affixed to the asset, because of the strength of the adhesive on the unit.

- If mounting on the side of an asset, the Pressure Equalizing Vent (PEV) on the unit must be pointing towards the ground. This ensures that the internal GPS antenna is pointing towards the sky for better accuracy.
- Networkfleet's standard is to install the unit on a stationary part of the asset, not a moving part (i.e. no lids, doors, hinges, etc.), with a clear view of the sky.
- Avoid snow and water accumulation. The AT-1400 is designed to be weatherproof, however if the device is left sitting in water/snow you may experience degraded antenna and GPS performance. The optimal operating temperature for the AT-1400 is -40 C to +85 C.
- Performance and/or functionality of the AT-1400 cannot be guaranteed if the unit is covered by metal.

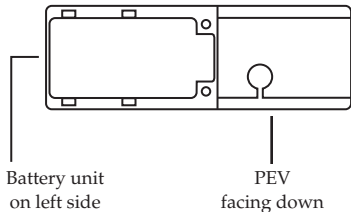

Once the battery is connected, the AT-1400 will be operable and begin reporting location and movement messages. We recommend that you allow 10 minutes for the unit to power up and obtain its first GPS reading. **The AT-1400 has no visible indicators to confirm that the device is operational.** To verify successful installation, call Customer Care at 866.227.7323 and select Option 5.

The AT-1400 includes a field replaceable battery. To replace:

1. Remove the two screws connecting the battery to the hardware unit.
2. Using a tool such as a flat head screwdriver, disengage the battery by placing the tool between where the unit and the battery meet.
3. Connect the new battery by placing it on the grooves of the hardware unit. Push down and slide the battery forward until the battery overlaps with the two through-holes (for screws) on the hardware unit; some force may be required.
4. Re-fasten the two original 8-32 x 1/2" torx screws to seal the battery and the unit together.
5. **The AT-1400 has no visible indicators to confirm that the device is operational.** Call Customer Care at 866.227.7323 and select Option 5 to verify that the replacement battery is functioning correctly.

If you have any additional questions, you may contact
Networkfleet Customer Care:

Toll Free Number: 866.227.7323

Fax: 815.361.9215

Email: customercare@networkfleet.com

www.networkfleet.com

Networkfleet

6363 Greenwich Drive, Suite 200

San Diego, California 92122



networkfleet

© 2010 Networkfleet. All rights reserved. Printed in U.S.A. v121610